

ITEM NO.	DESCRIPTION
1	Ø16"/ 400mm TOP MANWAY w/ 2" T.C. VENT
2	CUSTOMER LOGO
3	THREADED INSERT FOR TAG CLIP
4	THERMOWELL PORT: 1 1/2" T.C.
5	SAMPLE/ WASHING PORT: 2" T.C. W/ VALVE
6	Ø16"/ 400mm FRONT POMACE DOOR
7	RACKING PORT: 2" T.C.
8	RACKING ARM
9	DRAIN PORT: 2" T.C.
10	FIXED OR ADJUSTABLE SEISMIC HOLD DOWN LEGS

ITEM NO.	DESCRIPTION
11	TEMP. CONTROL: UPPER COIL GLYCOL FITTINGS: 3/4" F.P.T.
12	TEMP. CONTROL: LOWER COIL GLYCOL FITTINGS: 3/4" F.P.T.
13	REAR THERMOWELL PORT: 1 1/2" T.C.
14	TankNet PL-1- Specify 120VAC or 12VDC

CAPACITY: 476GAL [1802L]
WEIGHT: 4732LB [2151KG]

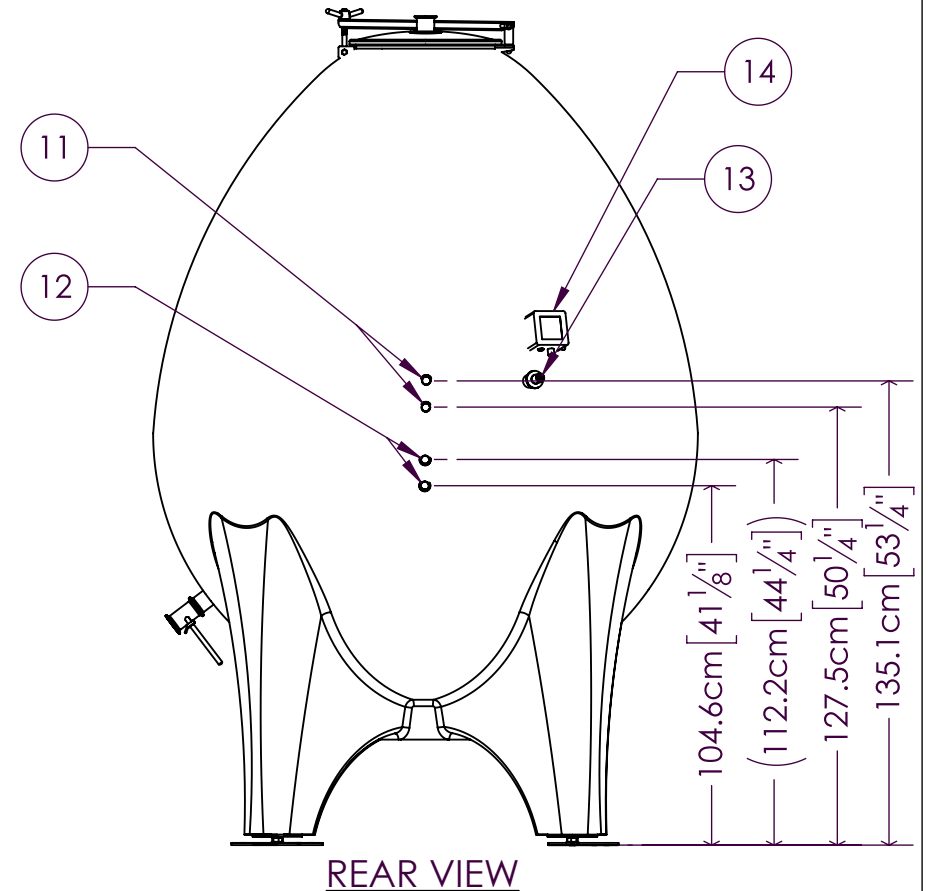
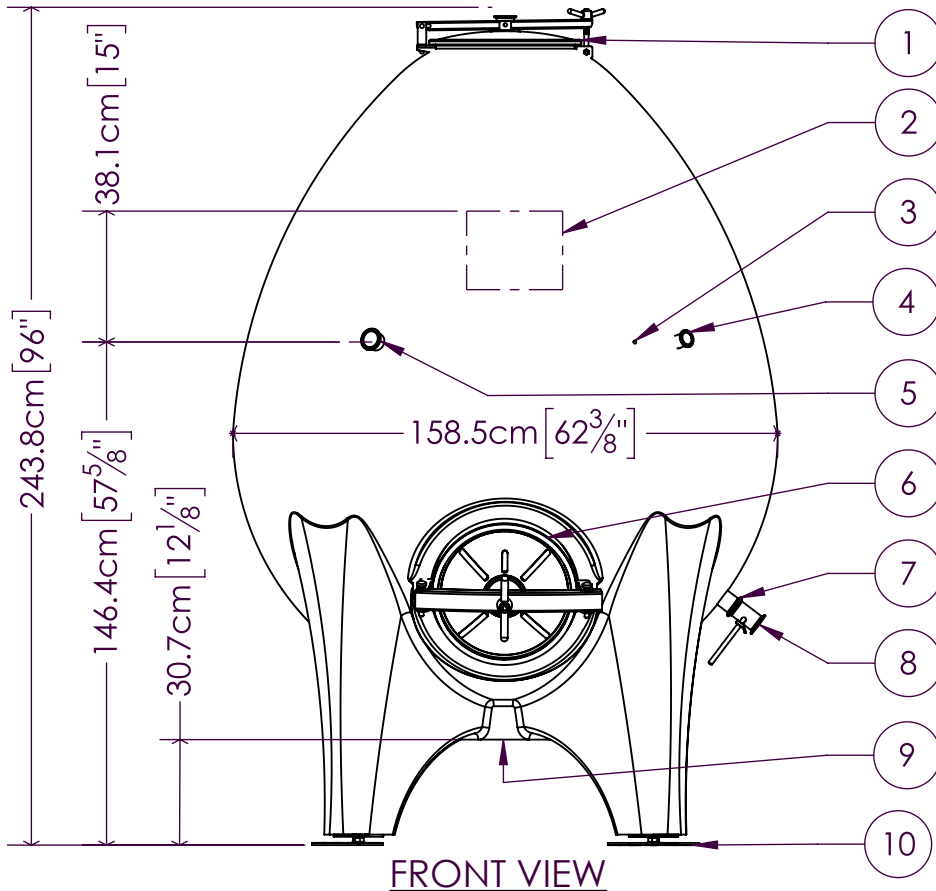

SONOMA CAST STONE
CONCRETE WINE TANKS

(877) 283-2400 www.concretewinetanks.com

EGG TANK SPECIFICATIONS- Standard and Optional Items

JOB NAME:

ORDER #

DATE: