

ITEM NO.	DESCRIPTION
1	Ø18"/ 460mm TOP MANWAY w/ 2" T.C. VENT
2	FILL PORT, 2" T.C., ANGLED
4	THREADED INSERT FOR TAG CLIP
5	CUSTOMER LOGO
6	THERMOWELL PORT, 1 1/2" T.C.
7	SAMPLE/ WASHING PORT: 2" T.C. W/ VALVE
8	Ø16"/ 400mm FRONT POMACE DOOR
9	RACKING PORT, 1 1/2" T.C.
10	DRAIN PORT, 1 1/2" T.C.
11	TANK TO TANK HOLD DOWN PLATES
12	SEISMIC HOLD DOWN LEGS
13	OXYGEN EMITTER PORT, 1 1/2" T.C.

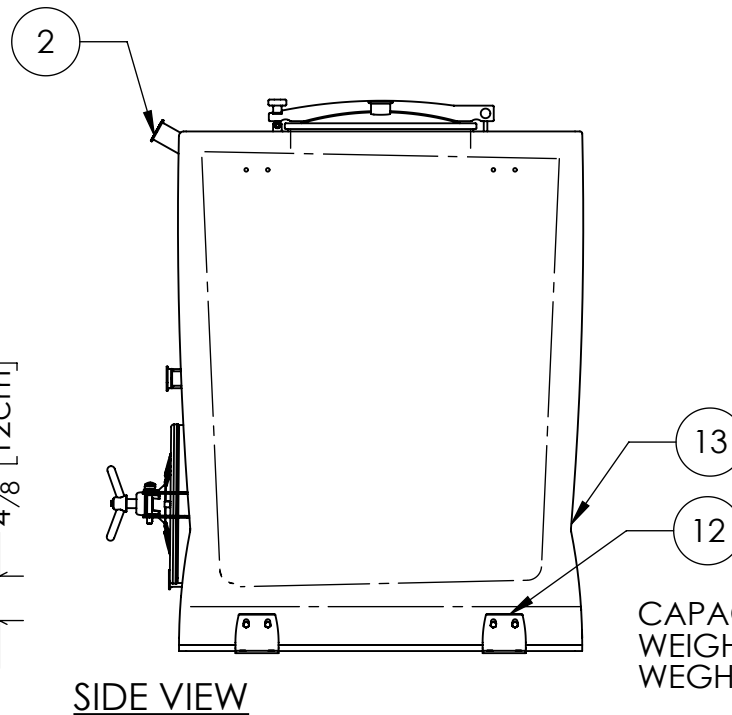

CAPACITY 240 GALLONS/ 908 LITER
 WEIGHT EMPTY: 2,780LB. [1,261kg]
 WEGHT FILLED: 4,820LB [2,186kg]

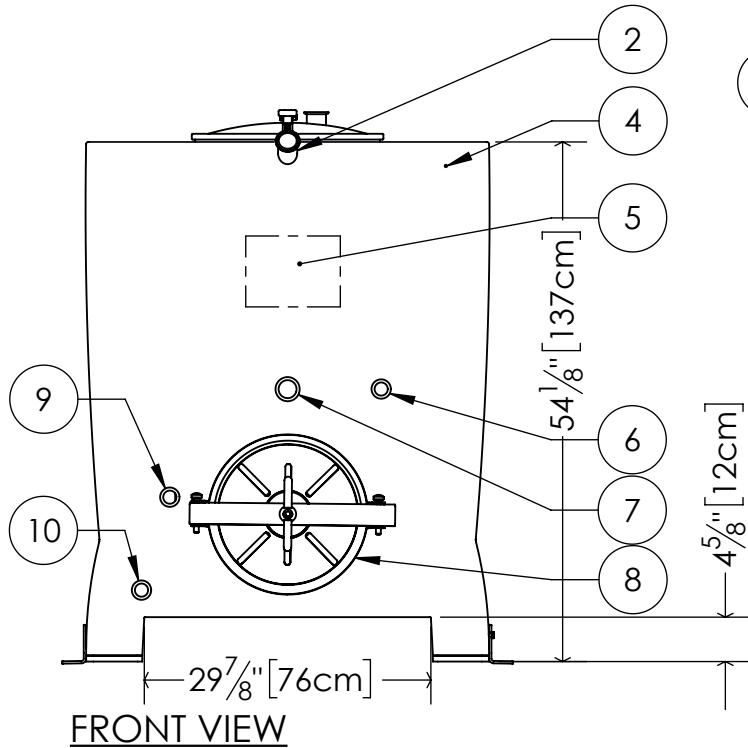

SONOMA CAST STONE
 CONCRETE WINE TANKS

(877) 283-2400 www.concretewinetanks.com

NUBARREL TANK SPECIFICATIONS- Standard and Optional Items

JOB NAME:	ORDER #	DATE:
-----------	---------	-------

THE EXTRA THICKNESS & STRENGTH OF THE NuBarrel® BASE ALLOWS STACKING 4 HIGH (2 BASE + 2 STANDARD) OR 3 HIGH (1 BASE + 2 STANDARD)

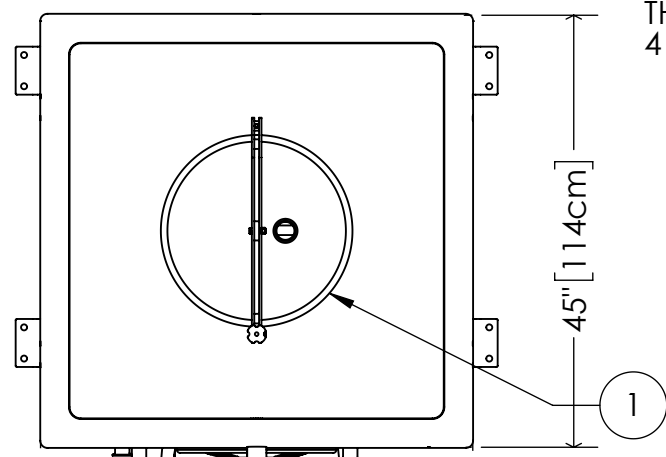

45" [114cm]
 CAPACITY 240 GALLONS/ 908L
 WEIGHT EMPTY: 4,214LB. [1,915kg]
 WEIGHT FILLED: 6,254LB [2,843kg]

TOP VIEW

ITEM NO.	DESCRIPTION
1	Ø18"/ 460mm TOP MANWAY w/ 2" T.C. VENT
2	FILL PORT, 2" T.C., ANGLED
4	THREADED INSERT FOR TAG CLIP
5	CUSTOMER LOGO
6	THERMOWELL PORT, 1 1/2" T.C.
7	SAMPLE/ WASHING PORT: 2" T.C. W/ VALVE
8	Ø16"/ 400mm FRONT POMACE DOOR
9	RACKING PORT, 1 1/2" T.C.
10	DRAIN PORT, 1 1/2" T.C.
11	TANK TO TANK HOLD DOWN PLATES
12	SEISMIC HOLD DOWN LEGS
13	OXYGEN EMITTER PORT, 1 1/2" T.C.
14	GLYCOL FITTINGS, 3/4" F.P.T
15	STAVE HOLDER WITH MANWAY TABS

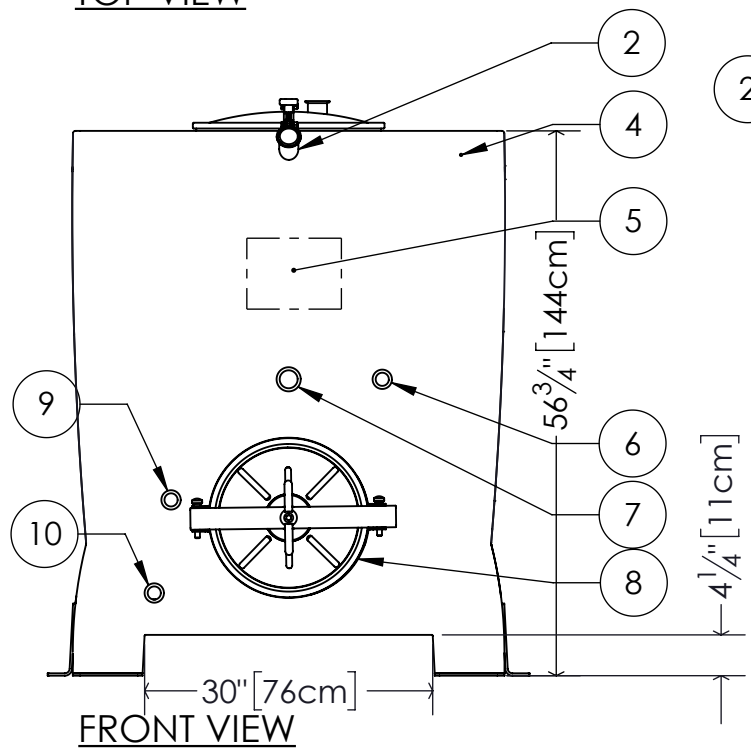

FRONT VIEW

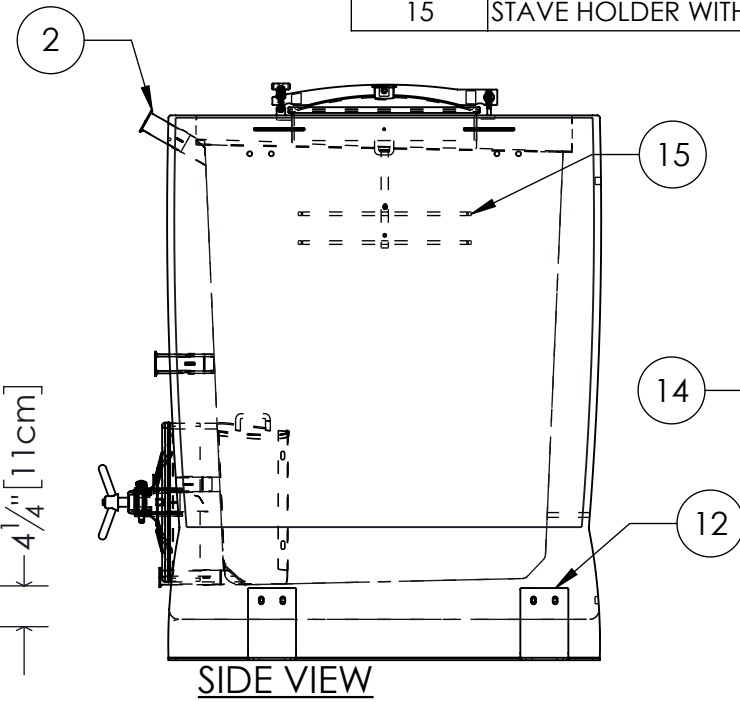

SIDE VIEW

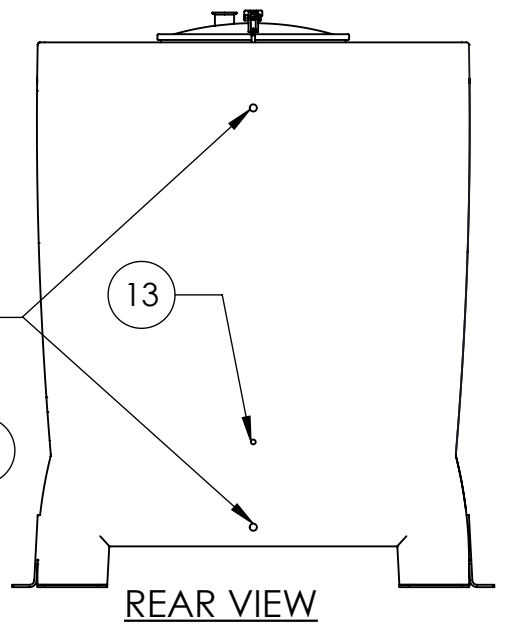

REAR VIEW



SONOMA CAST STONE
 CONCRETE WINE TANKS

(877) 283-2400 www.concretewinetanks.com

NuBarrel® BASE SPECIFICATIONS- Standard and Optional Items

JOB NAME:	ORDER #	DATE:
-----------	---------	-------