

Ø 559mm  
[22"]

2" T.C. VENT FITTING

HANDLE AND  
ALIGNMENT GUIDE

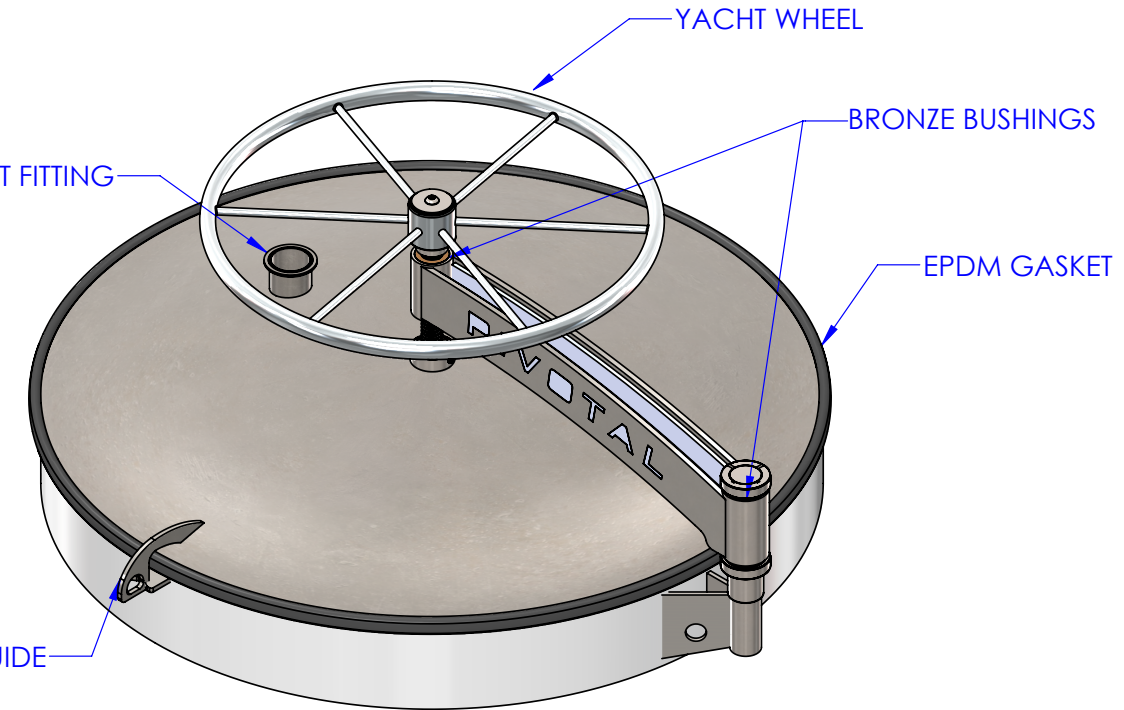

YACHT WHEEL

BRONZE BUSHINGS

EPDM GASKET

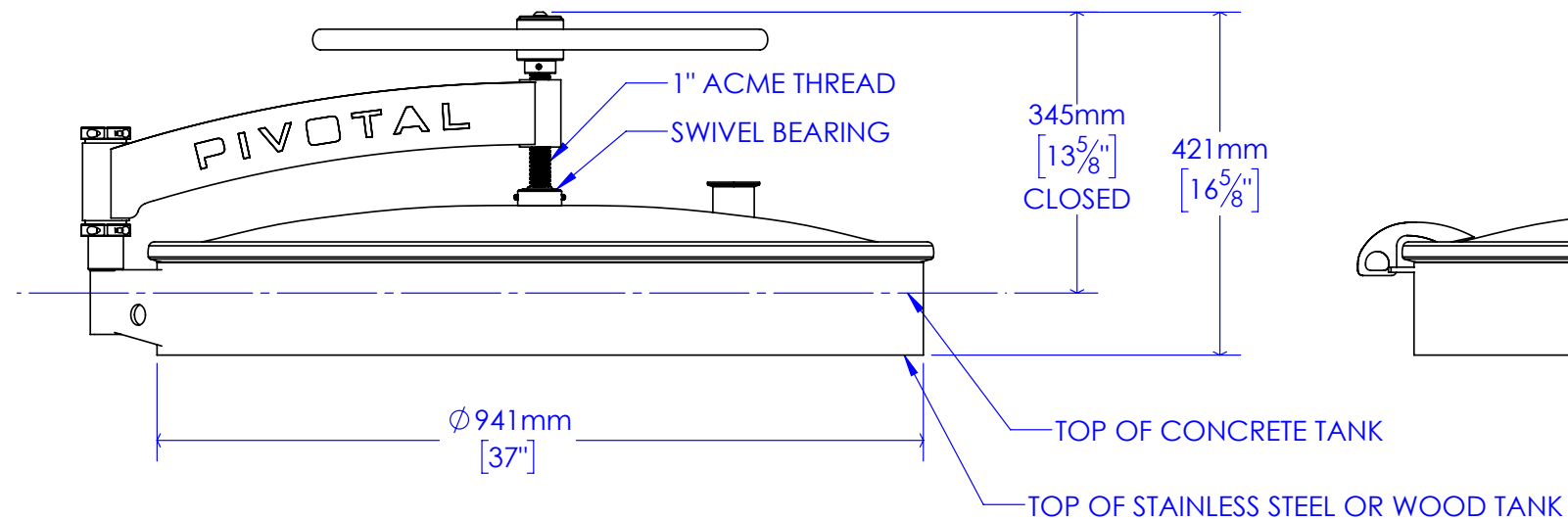

1" ACME THREAD  
SWIVEL BEARING

345mm  
[13<sup>5</sup>/<sub>8</sub>"]  
CLOSED

421mm  
[16<sup>5</sup>/<sub>8</sub>"]

Ø 941mm  
[37"]

TOP OF CONCRETE TANK

TOP OF STAINLESS STEEL OR WOOD TANK

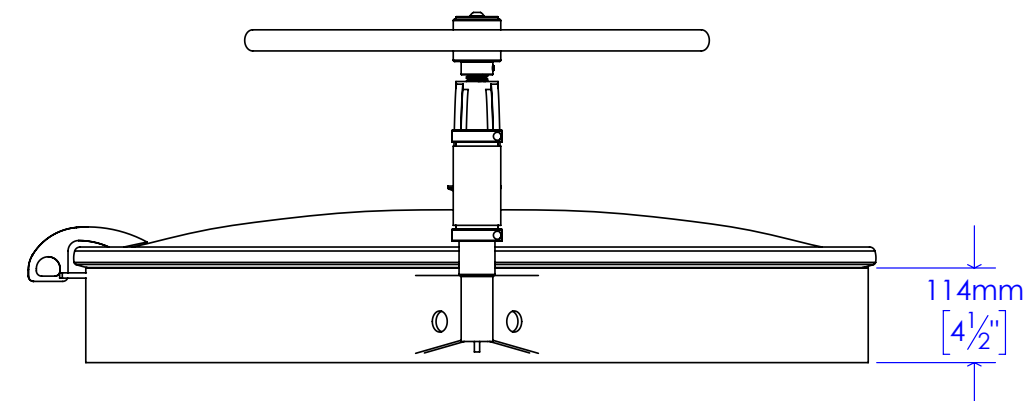

114mm  
[4<sup>1</sup>/<sub>2</sub>"]

**PROPRIETARY AND CONFIDENTIAL**

THE INFORMATION CONTAINED IN THIS DRAWING IS THE SOLE PROPERTY OF SONOMA CAST STONE CORP. ANY REPRODUCTION IN PART OR AS A WHOLE WITHOUT THE WRITTEN PERMISSION OF SONOMA CAST STONE CORP. IS PROHIBITED.